

Design and Development of Student Attendance Management System Using Intel Atom Processor

Suresh Cherukumalli^{1*} and A. Sudhir Babu²

^{1*,2}Dept of Computer Science and Engineering,
Prasad V Potluri Siddhartha Institute of Technology, Vijayawada, India
www.ijcseonline.org

Received: Aug/17/2015

Revised: Aug/26/2015

Accepted: Sep/21/2015

Published: Sep/30/2015

Abstract—The proposed work demonstrates the automation of students identification, bio-data and attendance maintenance which is one of the important tasks in college. But in case of large number it becomes difficult and clumsy. So to automate it, RFID's are used in this project we perform different functions like Identification of students, Attendance details with timing information. To detect the RFID tags, a software program is developed in Intel Atom Board with ARM 7Processor supporting Linux environment and Python Script along with GSM Modem and RF module detects the RFID tags. Whenever the RF tag comes into the vicinity of the RF reader, the GSM Modem sends SMS to the particular Parents. The main advantage of implementing student identification using Intel Atom Board is that the digital output can be directly connected to any P.C. and can monitor it continuously.

Keywords— RFID, Intel Atom Board, Linux, Python, ARM 7, GSM.

I. INTRODUCTION

The proposed work is designed to develop a record which maintains students profile relating their personal and professional details, to identify a person and to mark his/her attendance along with timing information automatically, thereby reducing the manual effort to a considerable extent. Hence the project "STUDENT IDENTIFICATION AND DETAILS USING RFID'S". Now a day it has become a big subject for maintaining student's details and identifying them in marking attendance. Hence the need has come out, thus this project work has taken up which serves the purpose of automation. By detecting RFID tag, the RF module marks the attendance automatically [1]. GSM modem is used to transmit data or messages to parents and all the data is stored in a database. And there is no possibility for manipulation of attendance [2], in time of students will be monitored perfectly. Since the system is based on RFID, we do have some hardware component in the application. This project throws more exposure on the radio frequency communication. As we know today, the modern communication plays a dominant role in modern civilization. The following figure shows the block diagram and system description of the proposed system.

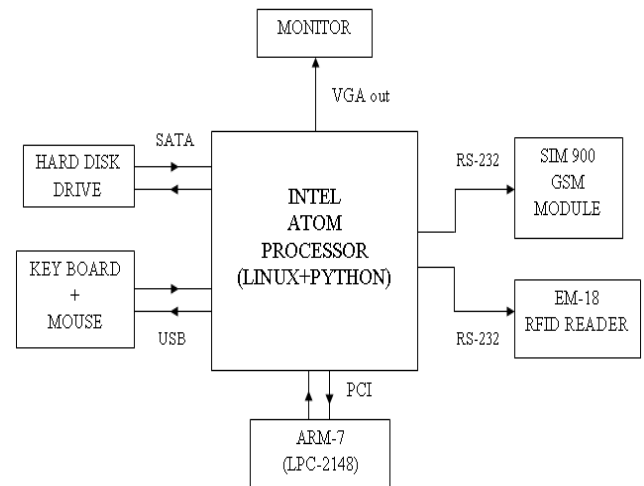

Figure 1: Block Diagram and System Description

II. INTEL ATOM BOARD

The Inforce® SYS9400 Reference Platform is a complete, ready-to-use developer kit that provides rich and flexible features to embedded and mobile system designers. Based on Intel® Atom™ technology specifically created for ultra-mobile computing, the SYS9400 offers outstanding performance in a small form-factor to optimize solutions for a variety of portable and fixed installation applications.

Corresponding Author: *Suresh Cherukumalli, RGPV, Bhopal*



Figure 2: Intel Atom Processor

The Intel Atom Board completely new microarchitecture with very little in common with other Intel PC processors. Designed with 3 primary goals: Dramatically reduce power consumption, sufficient performance for a full internet experience, Full x86 compatibility. The Inforce® SYS9400 platform supports all popular embedded software environments including Microsoft® Windows® XP, and Linux operating systems. Developers can leverage thousands of applications and tools that are already available for the PC desktop to accelerate their development cycle and time-to-market. The Intel Atom Board has the Technical Specifications of Intel Atom Processor E6xx series(0.6-1.6GHz, 512kb L2 cache, 800MHz FSB) and some additional features of Gigabit Ethernet, 2x SATA, SD Card Slot, VGA port, and serial ports RS-232/422/485, and it supports 12V @ 1A power supply.

III. EM-18 RFID READER

Radio-frequency identification (RFID) is the wireless use of electromagnetic fields to transfer data, for the purposes of automatically identifying and tracking tags attached to objects [6]. This is a low frequency (125 KHz) RFID reader with serial output at range of 8-12cm. It is compact units with built in antenna and can be directly connected to the PC using RS-232 protocol. The tags contain electronically stored information. Some tags are powered by electromagnetic induction from magnetic fields produced near the reader.

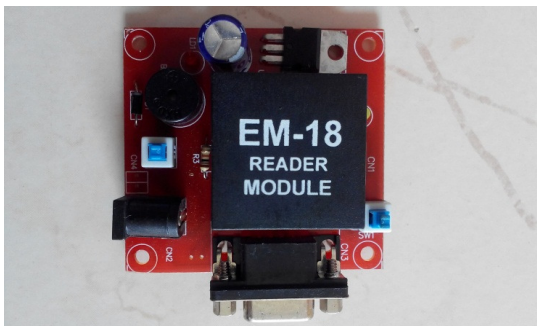

Figure 3: RFID Module

RFID module can be connected to Intel Atom Board by using RS-232 cable. The RS-232 cable is an interfacing module which is used for simple communication between micro controllers to micro controller. This has ability to communicating through in 3modes they are: Simplex mode, Half-Duplex mode, Full-Duplex mode. The RFID module requires external power supply of 5V.

IV. ARM 7(LPC2148 CONTROLLER)

ARM 7 is one of the widely used microcontroller family in embedded system application. ARM 7 Processor is based on Von Neumann Modal with a single bus for both data and Instruction (ARM 9 is a Harvard Modal). ARM 7 micro controllers to control all the peripherals. LPC2148 is used as MCU in this design. Because of the advanced 32 bit architecture, it can detect changes as low as 3 millivolts, faster compared to PIC's and other 80series micro controllers. Inbuilt ADC was an added benefit of LPC2148. Hence we used this as our micro controller unit. A Microchip microcontroller LPC2148 is used to collect, process the data and then stores it in a serial buffers. The LPC2148 is a 32k instructions program buffers, 512 kb bytes of RAM, three timers, and a 32-bit A/D converter microcontroller. It has RISC architecture and can use oscillators, thus it is ideal to be used as an embedded system.

V. GSM MODEM

Global system for mobile communication (GSM) is a globally accepted standard for digital cellular communication. It operates at either the 900 MHz or 1800 MHz frequency band. These modems are more frequently connected to computers which allow the computers to communicate with the mobile network. They are most probably used for sending/receiving SMS.

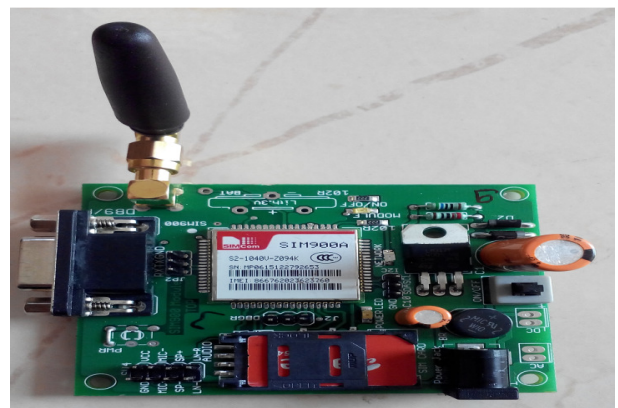

Figure 4: GSM Modem

GSM modem gives capability to send SMS without any mobile operating system. SIM card has to insert

in the GSM modem for its operation. SIM can be read with MCU and can be used to send SMS by micro controller. Hence a GSM modem was employed; its main function here was when the parameters are over threshold limits it sends a text message to predefined contacts about the situation of the person thus alerting them to precede for further actions. GSM modem can be connected to Intel Atom Board by using RS-232 cable. The GSM modem requires external power supply of 12V @ 1A.

VI. LINUX

Linux is an open source operating system that runs on a wide range of hardware platforms. Numerous Linux distributions are available from many companies, and each distribution has its own advantages and disadvantages. With these characteristics comes a faithful user following who think that their preferred distribution is the best. Some of the Linux distributions that are currently available include Red Hat, SUSE, Debian, and Mandrake. As Linux became popular, various versions have been created. The version we will use in class is Backtrack. At the heart of each distribution is the kernel, which interacts directly with the hardware. The kernel handles such functions as memory management, security, and resource Allocation. The kernel also provides features such as true multitasking, threading, and TCP/IP networking. Linux was specially developed as a free operating system for personal computers based on the Intel x86 architecture, but has since been ported to more computer hardware platforms than any other operating system. Thanks to its dominance on smartphones, Android, which is built on top of the Linux kernel, has the largest installed base of all general-purpose operating systems. Linux, in its original form, is also the leading operating system on servers and other big iron systems such as mainframe computers and supercomputers, but is used on only around 1.5% of desktop computers. Linux also runs on embedded systems, which are devices whose operating system is typically built into the firmware and is highly tailored to the system; this includes mobile phones, tablet computers, network routers, facility automation controls, televisions, video game consoles and smart watches.

The development of Linux is one of the most prominent examples of free and open-source software collaboration. The underlying source may be used, modified, and distributed—commercially or non-commercially—by anyone under licenses such as the GNU General Public License. Typically, Linux is packaged in a form known as a Linux distribution for both desktop and server use. Some of the popular mainstream Linux distributions are Debian, Ubuntu, Linux Mint, Fedora, opens SUSE, Arch Linux and Gentoo, together with commercial Red Hat Enterprise Linux and SUSE Linux Enterprise Server distributions. Linux distributions include

the Linux kernel, supporting utilities and libraries, and usually a large amount of application software to fulfill the distribution's intended use.

VII. PYTHON

Python offers dynamic data type, ready-made class, and interfaces to many system calls and libraries. It can be extended, using the C or C++ language. Once you have Python installed, you can choose your favorite editor to write your code. At Udacity, we like to use Sublime Text, which allows you to write and build code all in the same program. Sublime Text can be evaluated for free but you will need to purchase a license for continued use. Free options include for Mac and Notepad++ for PC. Beyond these basics, other options for writing and running Python code include 'integrated development environments' (IDES) which are packages that include everything you need to develop code in Python, such as IDLE or PyCharm. These packages can contain other features you may not need (or understand) as a beginner, and the set up process may be more involved.

VIII. WORKING

The designed system consists of Intel atom processor, ARM 7, GSM module, RFID reader shown in figure 5. Now a day it has become a big subject for maintaining student's details and identifying them in marking attendance. This project has been developed in Python language and Linux used as an operating system and the processor here used is Intel atom processor. In this we link the student ID cards (RFID CARDS) to mobile numbers of their parents with the help of code developed in python language.



Figure 5: A rear view of the Proposed System

We are using EM-18 RFID Reader as a card scanner. RFID Scanner is a plug-play USB device that has only one task – If a valid task is swiped in front of the scanner, the RFID tag is read and its unique code is pasted on any text field on the active window of the screen. Students are supposed to swipe their card in front of RFID Reader while entering into the college, if they are in time the message will be sent to their parents as present. Even if they are late by 1 minute the message will be sent as they are absent for that day to parents. GSM modem is used to transmit data or messages to parents and all the data is stored in a database. And there is no possibility for manipulation of attendance [2], in time of students will be monitored perfectly. Since the system is based on RFID, we do have some hardware component in the application.

To keep the project simple and more software based, we are not designing any hardware architecture to the software system. We are going for basic hardware used as an interfacing device to read the data from the card and store it on application’s database. The task of the scanner is to read a ten digit unique RFID tag and feed it to any display device or visible fields on the screen. So each card has a film with a 10 digit unique RFID and the number is printed on the card itself for recognition purpose.

IX. FLOW CHART

From figure 6, it initializes serial communication to load user id database and start timeout timer, check for timeout and if no wait for RFID then detect RFID and compare with id database, if it does not matches goes back to RFID, If it matches sets flag for user and gets parent number from database to send acknowledgement message. In the case of yes it gets user flags, non-active user details, and Parents mobile numbers and sends alert messages to parents.

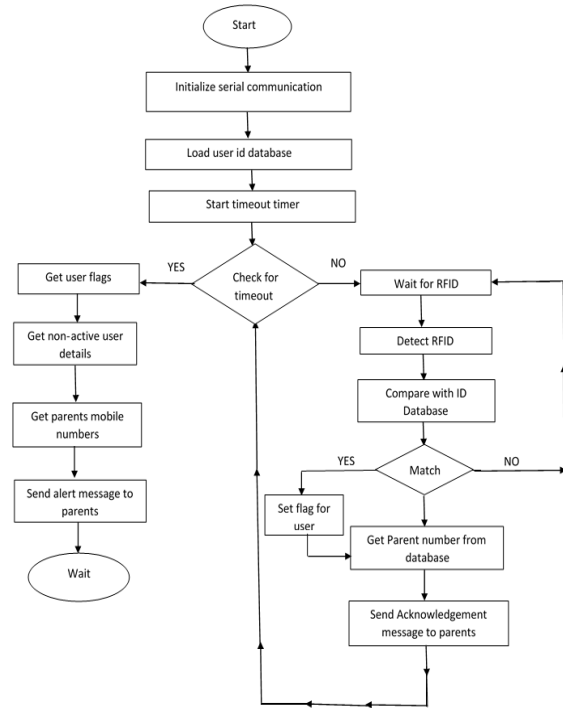

Figure 6: Proposed Flow Chart

X. RESULTS

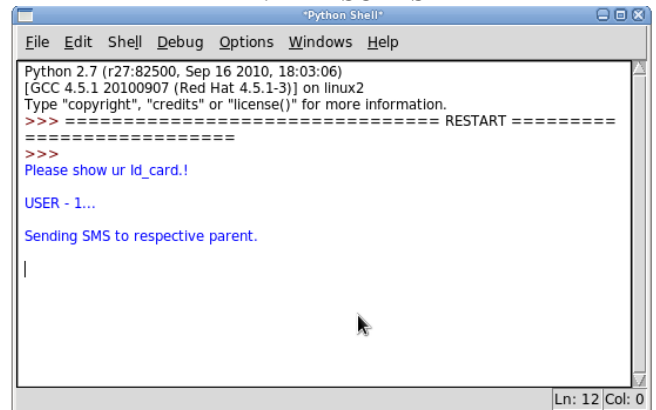

Figure 7: SMS Sending to Swiped Card Window

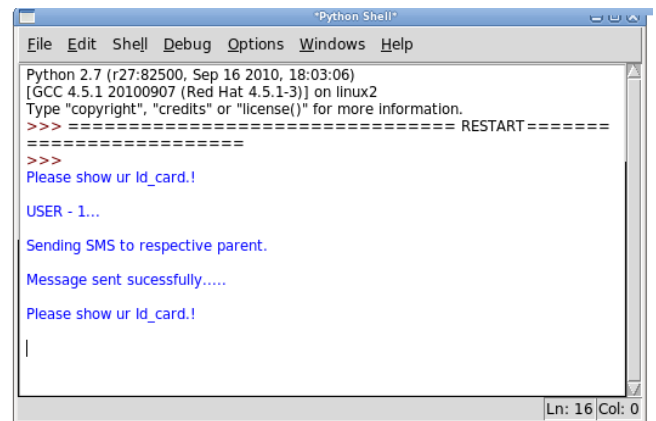

Figure 8: SMS Send Successful

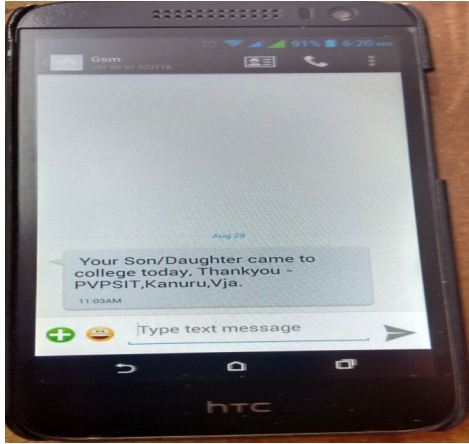

Figure 9: SMS Received Mobile (swiped card)

```

Python Shell
File Edit Shell Debug Options Windows Help
USER - 9...
Sending SMS to respective parent.
Message sent sucessfully.....
Please show ur Id_card.!
Timeout Occurred, No further cards are accepted.
User-2 Absent, Sending SMS..[]
Sending SMS to respective parent.
Message sent sucessfully.....
User-4 Absent, Sending SMS..[]
Sending SMS to respective parent.
Message sent sucessfully.....
User-6 Absent, Sending SMS..[]
Sending SMS to respective parent.
Message sent sucessfully.....
User-8 Absent, Sending SMS..[]
Sending SMS to respective parent.
Message sent sucessfully.....
User-10 Absent, Sending SMS..[]
Sending SMS to respective parent.
Message sent sucessfully.....
Ln: 79 | Col: 0

```

Figure 10: SMS Sending to UnSwiped Card Window

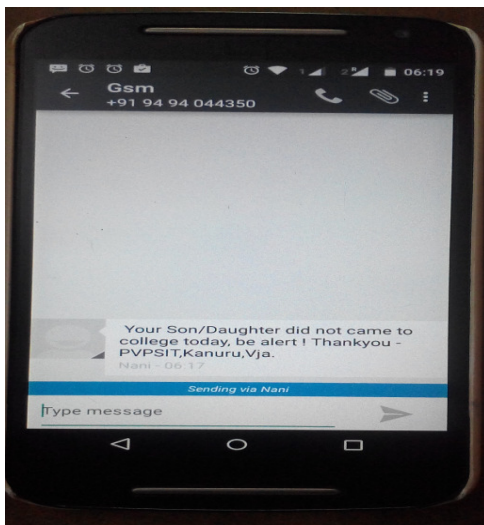

Figure 11: SMS Received Mobile (un swiped card)

XI. CONCLUSION

In every organization, for student bio-data and attendance, it takes huge volumes of papers, and it makes complex search process. Coming to student identification, manual approach involves some problems. It is better to have an automated tool to maintain above said things, which is simple, easy, and flexible to operate. Hence, the objective to build a Student attendance system using Intel Atom Processor, RFID Module, and GSM Modem was successfully achieved. Compared to micro controller the Intel Atom Processors performance is effective.

REFERENCES

- [1] Ononiwu G, Chiagozie, Okorafor G. Nwaji. "Radio Frequency Identification (RFID) Based Attendance System with Automatic Door Unit". In Academic Research International, ISSN: 2223-9553. **2012**; 2(2).
- [2] Zatin Singhal and Rajneesh Kumar Gujral. "Anytime Anywhere- Remote Monitoring of Attendance System based on RFID using GSM Network". In International Journal of Computer Applications (0975-8887). **2012**; 39(3).
- [3] Herdawatie Abdul Kadir, Mohd Helmy Abd. Wahab, Zarina Tukiran, Ariffin Abdul Mutalib. "Tracking Student Movement using Active RFID". In 9th WSEAS International Conference, ISSN: 1790-5117.
- [4] Elisabeth Ilie-Zudor, Zsolt Kemeny, Peter Egri, Laszlo Monostori. "The RFID Technology and its Current Applications" in MITIP-**2006**.
- [5] Mohd. Firdaus Bin Mahyidin. "Student Attendance Using RFID System". In University Malaysia, Pahang, May-2008.
- [6] L. Sandip, "RFID Sourcebook", IBM Press, USA, (**2005**) ISBN: 0-13-185137-3
- [7] E. Zeisel & R. Sabella, "RFID+", Exam Cram, (**2006**), ISBN: 0-7897-3504-0.

AUTHORS PROFILE



CH. Suresh is presently M.Tech Student, Dept. of Computer Science & Engineering, Prasad V Potluri Siddhartha Institute of Technology (Autonomous), Kanuru, India.



Dr. A. Sudhir Babu is presently Professor, Dept. of Computer Science & Engineering, Prasad V Potluri Siddhartha Institute of Technology (Autonomous), Kanuru, India.