

# Design and Implementation of Reconfigurable Virtual Instruments with User Defined Functionality

Jeevitha L<sup>1\*</sup>, Sangeetha S<sup>2</sup> and Arun pandiyan S<sup>3</sup>

<sup>1,2,3</sup>Department of EEE, V.R.S. College of Engineering and Technology, Villupuram  
 jeevitha\_87@yahoo.com<sup>1</sup>, sangeetha.s57@gmail.com<sup>2</sup>, sks.arun@gmail.com<sup>3</sup>

[www.ijcaonline.org](http://www.ijcaonline.org)

Received: 12/04/2014 Revised: 08 /05/2014 Accepted: 18/05/ 2014 Published: 31 /05/2014

**Abstract** - Reconfigure multiple instruments in single hardware platform. In this project a low cost arbitrary waveform generator, Function generator, Digital Oscilloscope is proposed with low end microcontroller – ARM LPC2148 which would generate a waveform of any shape and type required for functionality defined by user. The embedded hardware regenerates the user defined waveform with appropriate magnitude and frequency. The hardware is implemented with SDRAM support to make it portable, so that the user can download the standard and Non-standard type of waveform into the target hardware and generate the output waveform in oscilloscope. A high-level software application runs on the PC and provides a user interface to the operator select a virtual instrument (e.g. digital oscilloscope, arbitrary waveform generator, function generator...) from a library of instruments and configures the RVI system to convert it into the selected instrument with its associated console.

**Keywords** – Function generator, Digital storage oscilloscope, Arbitrary wave generator, Zigbee, ARM LPC 2148

## INTRODUCTION

Reconfigure multiple instruments in a single hardware platform. Virtual instruments are software defined instruments and card based modular hardware is used. It is specified only for testing multiple instruments. It minimizes the cost and complexity of hardware. Arbitrary waveform generators, Function generator, Oscilloscope are very essential in test and evaluation of prototype hardware which require signal inputs of standard and non-standard type.

The front panel of our application software comprises of a ‘Waveform chart’ in which the user will draw the waveform of his choice and type in PC. Provisions for generating the standard waveforms are also given in the application software. Development of ‘Device Driver’ is also done to make the hardware ‘General purpose programmable’ for the reconfigurable virtual instruments.

8 bit Serial communication between the PC and the embedded processor is established via the serial port and the serial interface hardware at a standard baud rate of 9600. The hardware part includes a ARM LPC2148 microcontroller which accepts data from PC using serial interface and delivers the output to the waveform generation hardware DAC depending upon the magnitude and frequency.

Firmware is written using KEIL compiler Embedded-‘c’ microcontrollers. Main software module includes initializing and managing serial data, waveform generation based on the command from the application software, driving the in-built waveform generation hardware. Finally the output is generated in oscilloscope with appropriate amplitude and frequency.

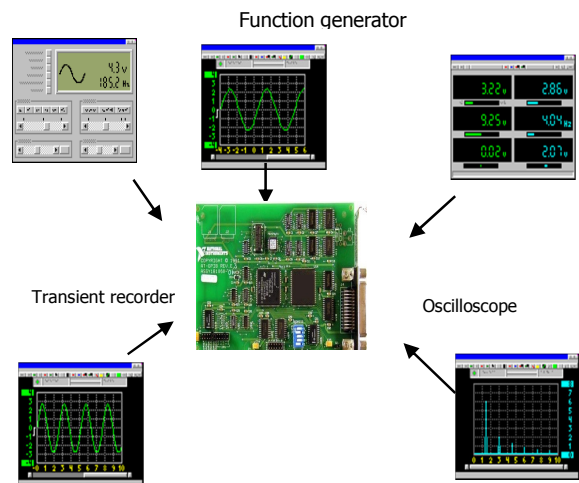

Figure 1: Reconfigurable virtual instruments

Design a low-cost reusable multiple electronic and scientific instrumentation system in single hardware platform. Multiple applications is specified in Reconfigurable microcontroller hardware Function generator, Oscilloscope, Multi-meter, Transient recorder, Spectrum analyzer, Arbitrary waveform generator

The concept of VI involves signal acquisition, processing, analysis, storage, distribution and presentation of data and information related to the measurement of one or more signals, the user-machine interface, process monitoring, communication with other teams, etc.

The advantages of virtual instruments are the following:

- Increased flexibility as it is possible to reconfigure the software.

Corresponding Author: Jeevitha L

- Increased life of the system by adapting it to future needs.
- They require smaller software system to create multiple functionalities for the same measurement hardware. In this case a data acquisition card (DAQ).
- Lower cost of the system because the hardware can be reused.
- Ability to meet the system requirements that cannot be covered by traditional instruments at reasonable cost.

**II. PROPOSED RECONFIGURABLE VIRTUAL INSTRUMENTS**

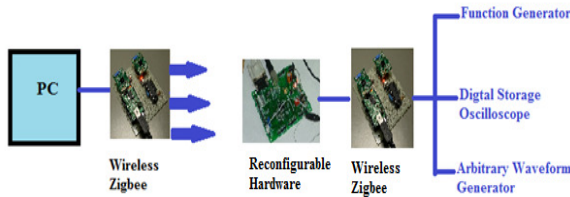

Figure 2: Reconfigurable multiple instruments in single hardware

Reconfigure virtual instruments in single hardware platform. With different configuring algorithm same hardware is used for different kind of instrument functions. Hardware instrument can be re-programmed. Possible to construct multifunctional Instrument. Flexibility in terms of handling the overall functionality of the instrument. It is Cost Effective.

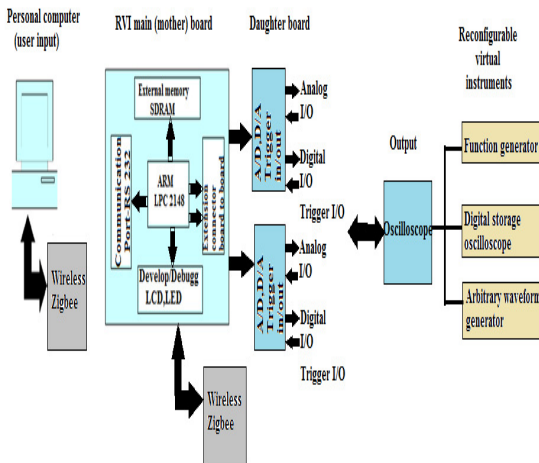

Figure 3: Block diagram of Reconfigurable virtual instruments

In this project a low cost, arbitrary waveform generator is proposed with ARM-LPC2148 microcontroller. The user shall draw the waveform of any shape of his choice by using mouse in the user interface provided by application software. In that waveform sampling to be done. It is interface to the hardware through communication ports such as RS 232, USB, and Ethernet. The user can download arbitrary data into hardware using serial ports.

For example: In waveform 200 samples of data are sent from PC, it is stored in 512K of on-chip flash memory, if memory usage is excess SDRAM external memory with battery pack up will store all data. The microcontroller is digitized the sampled values.

Therefore 200 samples of data stored in RAM. The microcontroller retrieve all data through external connectors from Motherboard to Daughter board is in-built given to waveform generated hardware DAC. Trigger in/out is clock source for internal or external operations. For developing and debugging facilities LCD, LED, Push buttons are switches used to turn 'on' and 'off' for processing.

Embedded hardware regenerate user defined waveform with appropriate amplitude and frequency. Finally the waveform is generated in Oscilloscope without change of amplitude and frequency defined by user.

Design a low-cost reusable multiple electronic and scientific instrumentation system in single hardware platform. Multiple applications is specified in reconfigurable microcontroller hardware Function generator, Oscilloscope, Arbitrary waveform generator. It is specified only for testing purpose.

**III. EXPERIMENTAL RESULTS**

*A. Software Implementation*

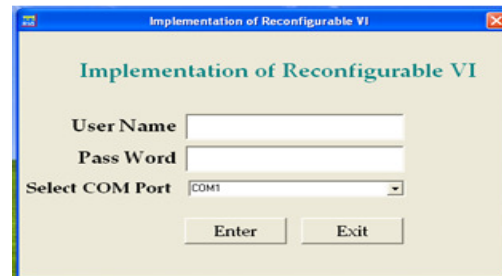

Figure 4: User Window

The front panel of arbitrary wave generator using application software. It is user window consist of user id and password. Application software provides set of library functions communicate with hardware. Enter user name and password of Log in window.



Figure 5: Selecting virtual instruments

Using application software virtual instruments are selected. Function generator, Oscilloscope and arbitrary waveform generator are the applications used in virtual instruments.

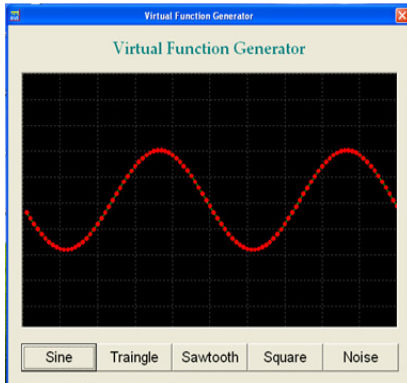

Figure 6:Function generator

It is Electronic testing equipment. Generate sine, square, triangle, saw tooth, noise. Use in development, testing and repair electronic-equipment

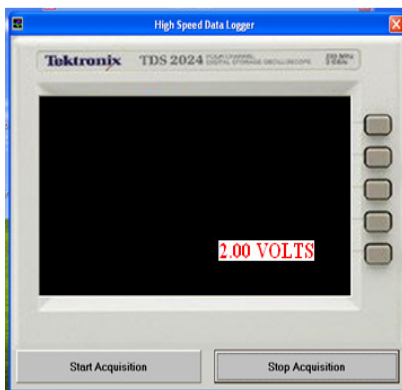

Figure 7:Digital storage oscilloscope

A digital storage oscilloscope is an oscilloscope which stores and analyses the signal digitally rather than using analogue techniques. The advanced trigger, storage, display and measurement features .The input analogue signal is sampled and then converted into a digital record of the amplitude of the signal at each sample time

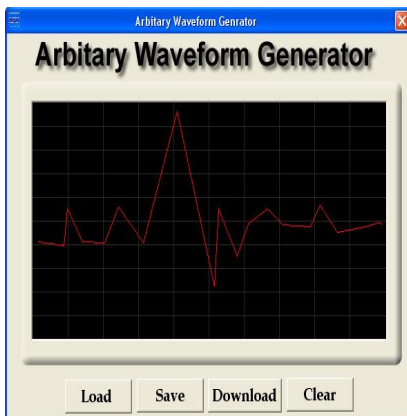

Figure 8:Arbitrary waveform generator

Wave form is consisting of Non-standard type. It also generates standard waveforms like sine, square, triangle and saw tooth. In 'Waveform chart' the user shall draw the waveform of any shape. The waveform is saved by creating a new folder in desktop. It is used to clear the waveform. The saved waveform is again loaded in 'waveform chart'. Sampling is done in waveform and then it is downloading into hardware.

### B. Hardware Implementation

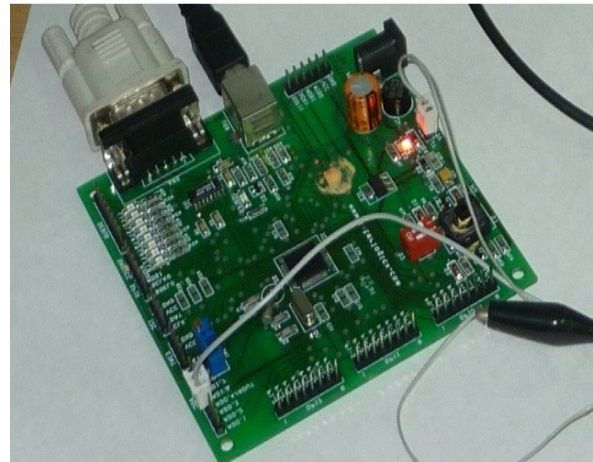

Figure 9:ARM LPC 2148

64-pin High-Performance ARM Micro controller. Flash Program Memory is 512 KB.SRAM Data Memory is 32 KB.I/O Pins is 45.Timers is Two 32-bit.A/D Converter is 10-bit Fourteen Channels.DAC is 10-bit.Real-Time Clock (RTC) is Independent Power and Dedicated 32kHz Input.I<sup>2</sup>C is Two Modules with Master or Slave Operation.SPI is Full Duplex Serial Operation..UART is Two Modules.USB is 2.0B Fully Compliant Controller with RAM..External Oscillator is up to 25MHz with integrated PLL for 60MHz Operation.



Figure 10: Digital storage oscilloscope

A digital storage oscilloscope is an oscilloscope which stores and analyses the signal digitally rather than using analogue techniques. The advanced trigger, storage, display and measurement features .The input analogue signal is sampled and then converted into a digital record of the amplitude of the signal at each sample time.



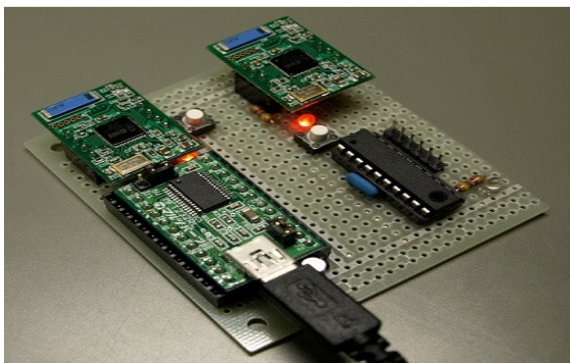

Figure 11: Wireless Zigbee

Zigbee is a high level communication protocols used to create personal area networks built from small, low-power digital radios. It is used in applications that require only a low data rate, long battery life, and secure networking.

#### IV. CONCLUSION

In this project a low cost Function generator, Oscilloscope, arbitrary waveform generator is proposed with low end microcontroller which would generate a standard and Non-standard type of waveform required for functionality defined by user. The front end design of virtual instruments is reconfigured. Hardware is implemented. Finally the output is generated in oscilloscope with same amplitude and frequency defined by user. Wireless Zigbee monitoring functions is implemented. In future Spectrum analyzer, Transient recorder and Multi-meter is reconfigured.

#### REFERENCES

- [1] E.Chuang, S. Hensley; K. Wheeler, "A Highly Capable Arbitrary Waveform Generator for Next Generation Radar Systems," IEEE Aerospace Conference, Big Sky, Montana, USA, March 2006, digest.
- [2] M.Chen yun yun, A.Yang Zhou, R.Xiao cloud, "Design of virtual function signal generator", International conference on energy and environment technology, April 2009
- [3] S.Marcin Iwanowicz, A. Zbigniew Pioro, M.Lidia Łukasiak, "Arbitrary waveform generator for charge pumping" journal of tele-communication and information technology" 2011
- [4] D. Qiu, Q. Li, F. Zhou, "Design of Arbitrary Waveform generator Based on SDRAM," International Conference on Electronic Measurements & Instruments, Beijing, China, August 2009, digest.
- [5] Thomas Alpert, A.Marc werz ,F. "Arbitrary waveform generator based on FPGA and High speed DAC with real-time interface" International conference on control automation and system engineering, 2012.
- [6] M. B. Yeary, R. J. Fink, D. Beck, D.W. Guidry, M. Burns, "A DSP Based Mixed-Signal Waveform Generator," IEEE Transactions on Instrumentation and Measurement, June 2004, vol. 53, no.3, pp.665-671.
- [7] A.Yong Zheng, R.Xiaohan Guan Yuquan,S.Wang Wenjia "Design of portable virtual instruments with USB interface" IEEE conference on virtual instruments, 2010.
- [8] T. Zhen Alpert, F. Lang, M. Grözing and M. Berroth, "A 28 GS/s 6 bit CMOS DAC with Real-Time Interface," European Solid-State Circuits Conference, Helsinki, Finland, September 2011, Fringe Poster Session
- [9] D. Zhou Ferenci, M. Berroth, "A 100 Gigabit Measurement System with State of the Art FPGA Technology for Characterization of High Speed ADCs and DACs," Prime, Berlin, Germany, July 2010, digest

- [10] A.Zingh zen, R.Yong "FPGA-based reconfigurable measurement instruments with functionality defined by user" EURASIP Journal on Applied Signal Processing, 2006