

Review paper on Cell Free Massive MIMO Systems with FDD and TDD based Channel State Information

Swati Sharma^{1*}, Sanket Choudhary², Bharti Gupta³

^{1,2,3}Department of Electronics and Communication, LNCTS, Bhopal

Corresponding Author: sswatisharma29@gmail.com

DOI: <https://doi.org/10.26438/ijcse/v7i7.271275> | Available online at: www.ijcseonline.org

Accepted: 19/Jul/2019, Published: 31/Jul/2019

Abstract— In a cellular network, the demand for high throughput and reliable transmission is increasing in large scale. One of the architectures proposed for 5G wireless communication to satisfy the demand is Massive MIMO system. The massive system is equipped with the large array of antennas at the Base Station (BS) serving multiple single antenna users simultaneously i.e., number of BS antennas are typically more compared to the number of users in a cell. The advantages of massive MIMO can be achieved only if Channel State Information (CSI) is known at BS uplink and downlink operate on orthogonal channels - TDD and FDD modes. Depending on slow/fast channel fading conditions, several authors suggested adaptive LMS, RLS and NLMS based channel estimators, which either require statistical information of the channel or are not efficient enough in terms of performance or computations. In order to overcome the above effects, the work focuses on the QR-RLS based channel estimation method for cell free Massive MIMO systems.

Keywords: - Massive MIMO, Channel State Information, Square Root-Recursive Least Square (QR-RLS)

I. INTRODUCTION

The demand for wireless throughput has grown exponentially in the past few years, with the increase in a number of wireless devices and number of new mobile users. The throughput is the product of Bandwidth (Hz) and Spectral efficiency (bits/s/Hz) [1]. To increase the throughput, either Bandwidth or Spectral efficiency has to be increased. Since increasing the Bandwidth is a costly factor, the spectral efficiency has to be taken into consideration. It can be increased by using multiple antennas at the transmitter and receiver. Multiple-Input Multiple Output (MIMO) antennas enhance both communication reliability as well as the capacity of communication (by transmitting different data in different antennas). Generally MIMO systems are divided into two categories: Point-to-Point MIMO and Multi User - MIMO (MU-MIMO) [2], [3]. In Point-to-Point MIMO, both the transmitter and receiver are equipped with multiple antennas. The performance gain can be achieved by using the techniques such as beamforming and spatial multiplexing of several data streams. On the other hand, in MU-MIMO, the wireless channel is spatially shared among the users. The users in the cell transmit and receive data without joint encoding and joint detection among them. The Base Station (BS) communicates simultaneously with all the users, by exploiting the difference in spatial signatures at the BS antenna array. MIMO systems are incorporated in several new generation wireless standards like LTE - Advanced, Wireless LAN etc.

The main challenge in MU-MIMO system is the interference between the co-channel users. Hence, complex receiver technique has to be used, to reduce the co-channel interference. In [4], it is shown that by using an infinite number of antennas at the BS in comparison with the number of users in the cell, the random channel vectors between users and the BS become pair-wise orthogonal. By introducing more antennas at the BS, the effects of uncorrelated noise and intra cell interference disappear and small scale fading is averaged out. Hence, simple matched filter processing at BS is optimal.

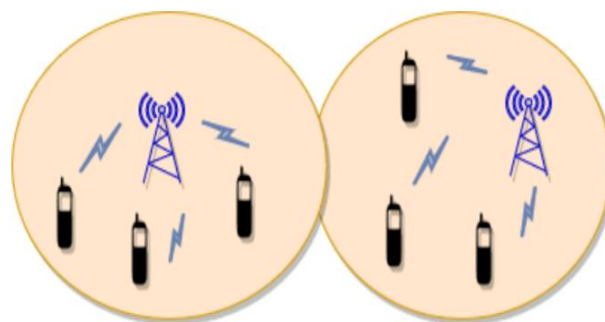

Figure 1: Multi-cell Massive MIMO System

MU-MIMO system with hundreds of antenna at the BS which serves many single antenna user terminals simultaneously at same frequency and time is known as Massive MIMO system or large antenna array MU-MIMO

system [5],[6]. One of the architectures proposed for 5G wireless communication is the massive MIMO system in which BS is equipped with a large number of antennas and serves multiple single antenna user terminals as shown in Fig 1.

Advantages of Massive MIMO System:-

High energy efficiency: If the channel is estimated from the uplink pilots, then each user's transmitted power can be reduced proportionally to $1/\sqrt{M}$ considering M is very large. If perfect Channel State Information (CSI) is available at the BS, then the transmitted power is reduced proportionally to $1/M$ [7]. In the downlink case, the BS can send signals only in the directions where the user terminals are located. By using the Massive MIMO, the radiated power can be reduced achieving high energy efficiency.

- **Simple signal processing:** Using an excessive number of BS antennas compared to users lead to the pair-wise orthogonality of channel vectors. Hence, with simple linear processing techniques both the effects of inter user interference and noise can be eliminated.
- **Sharp digital beamforming:** With an antenna array, generally analog beamforming is used for steering by adjusting the phases of RF signals. But in the case of Massive MIMO, beamforming is digital because of linear precoding. Digital beamforming is performed by tuning the phases and amplitudes of the transmitted signals in baseband. Without steering actual beams into the channels, signals add up in phase at the intended users and out of phase at other users. With the increase in a number of antennas, the signal strength at the intended users gets higher and provides low interference from other users. Digital beamforming in massive MIMO provides a more flexible and aggressive way of spatial multiplexing. Another advantage of digital beamforming is that it does not require array calibration since reciprocity is used.
- **Channel hardening:** The channel entries become almost deterministic in case of Massive MIMO, thereby almost eliminating the effects of small scale fading. This will significantly reduce the channel estimation errors.
- **Reduction of Latency:** Fading is the most important factor which impacts the latency. More fading will leads to more latency. Because of the presence of Channel hardening in Massive MIMO, the effects of fading will be almost eliminated and the latency will be reduced significantly.
- **Robustness:** Robustness of wireless communications can be increased by using multiple antennas. Massive MIMO have excess degrees of freedom which can be used to cancel the signal from intentional jammers.

- **Array gain:** Array gain results in a closed loop link budget enhancement proportional to the number of BS antennas.
- **Good Quality of Service (QoS):** Massive MIMO gives the provision of uniformly good QoS to all terminals in a cell because of the interference suppression capability offered by the spatial resolution of the array. Typical baseline power control algorithms achieve max-min fairness among the terminals.
- **Autonomous operation of BS's:** The operation of BS's is improved because there is no requirement of sharing Channel State Information (CSI) with other cells and no requirement of accurate time synchronization.

Cell Free Massive MIMO

It also has the capacity to overcome many of the disadvantages of massive MIMO. Cell free massive MIMO also tells us about many advantages such as [3] its huge throughputs, Its high coverage probability along with the micro-diversity gain, small scale fading or its capability to control the average uncorrelated noise cell free massive MIMO can only be deviated by large scale fading [4].

It is very clear that performance of cell free massive MIMO is better than small cell system. It provides almost 20 folds and 95% likely per users throughputs [5]. Distributed APs are connected with CPU by a high backhaul capacity link in cell free massive MIMO.

While the problems arise due to limited backhaul link are considered in [5] and so also we have analyzed the hindrances caused by zero forcing reading designing in paper [6].

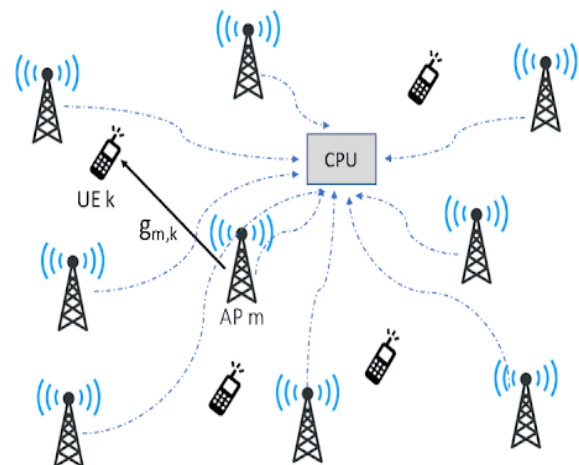

Figure 2: Cell free massive MIMO system

II. CHALLENGES

Propagation Model: In most of the Massive MIMO related works, the assumption that made was: as the BS antennas grow the user channels are uncorrelated and the channel

vectors become pair-wise orthogonal. But in real time propagation environment, antenna correlation comes into the picture. If the antennas are highly correlated, then the channel vectors cannot become pair-wise orthogonal by increasing the number of antennas. This means that users location is an important factor in Massive MIMO systems.

Modulation: For the construction of a BS with a large number of antennas, cheap power efficient RF amplifiers are needed.

Channel Reciprocity: TDD operation depends on channel reciprocity. There seems to be a reasonable consensus that the propagation channel itself is basically reciprocal unless the propagation is suffering from materials with strange magnetic properties. Between the uplink and the downlink, there is a hardware chain in the base station and terminal transceivers may not be reciprocal.

Channel Estimation: To perform detection at the receiver side, we need perfect CSI at the receiver side. Due to the mobility of users in MU case, channel matrix changes with time. In high mobility case, accurate and time acquisition of CSI is very difficult. FDD Massive MIMO induces training overhead and TDD Massive MIMO relies on channel reciprocity and training may occupy a large fraction of the coherence interval.

Low-cost Hardware: Large number of RF chains, Analog-to-Digital converters, Digital-to-Analog converters are needed.

Coupling between antenna arrays: At the BS side, several antennas are packed in a small space. This causes mutual coupling in between the antenna arrays. Mutual coupling degrades the performance of Massive MIMO due to power loss and results in lower capacity and less number of degrees of freedom. When designing a Massive MIMO system, the effect of mutual coupling has to be taken into account [8], [9].

Mobility: If the mobility of the terminal is very high, then the coherence interval between the channel becomes very less. Therefore, it accommodates very less number of pilots.

- **Pilot Contamination:** Pilot contamination is a challenging problem for multicell massive MIMO is to be resolved. In multicell system, users from neighboring cells may use non-orthogonal pilots that result in pilot contamination. This causes inter-cell interference problem which further grows with the increase in a number of BS antennas.

III. CHANNEL ESTIMATION

In order to achieve the benefits of a large antenna array, accurate and timely acquisition of Channel State Information (CSI) is needed at the BS. The need for CSI is to process the

received signal at BS as well as to design a precoder for optimal selection of a group of users who are served on the same time-frequency resources. The acquisition of CSI at the BS can be done either through feedback or channel reciprocity schemes based on Time Division Duplex (TDD) or Frequency Division Duplex (FDD) system. The procedure for acquiring CSI and data transmission for both systems is explained in the subsequent sections.

Channel Estimation and Data Transmission in TDD System

In TDD system, the signals are transmitted in the same frequency band for both uplink and downlink transmissions but at different time slots. Hence, uplink and downlink channels are reciprocal. During uplink transmission, all the users in the cell synchronously send the pilot signal to the BS. The antenna array receives the modified pilot signal by the propagation channel. Based on the received pilot signal, BS estimate the CSI and further, this information is used to separate the signal and detect the signal transmitted by the users as shown in Fig 3. In downlink transmission, due to channel reciprocity, BS uses the estimated CSI to generate precoding/beamforming vector. The data for each user is beam formed by the precoded vector at the BS and transmitted to the user through propagation channel as shown in Fig 4.

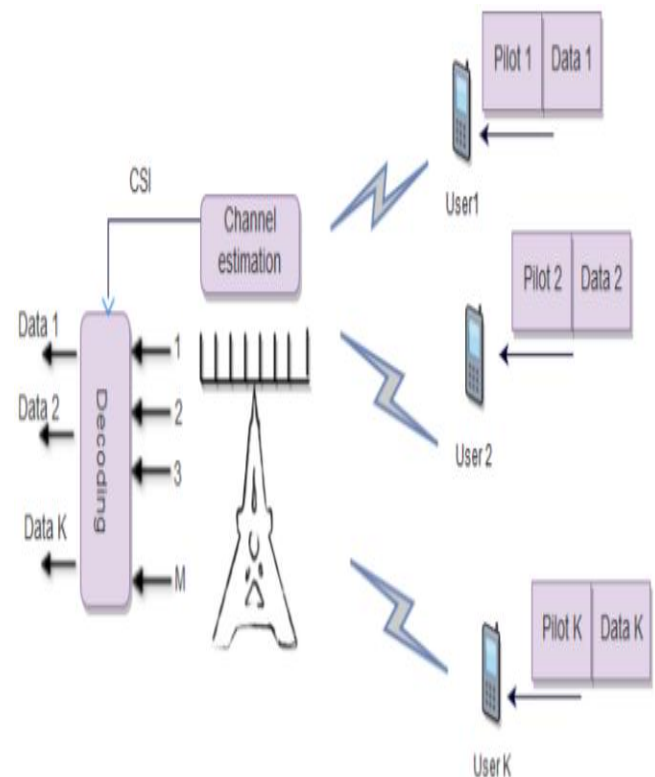

Figure 3: Uplink transmission in a TDD Massive MIMO system

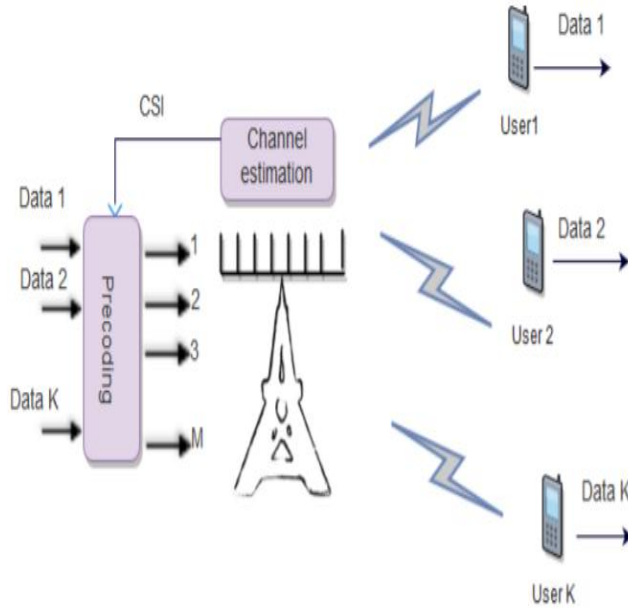

Figure 4: Downlink transmission in a TDD Massive MIMO system

Channel Estimation and Data Transmission in FDD System

In FDD system, the signals are transmitted at different frequency band for uplink and downlink transmission. Therefore, CSI for the uplink and downlink channels are not reciprocal. Hence, to generate precoding/beamforming vector for each user, BS transmits a pilot signal to all users in the cell and then all users feedback estimated CSI of the downlink channels to the BS as shown in Fig. 5. During uplink transmission, BS needs CSI to decode the signal transmitted by the users. To detect the signal transmitted by the user, CSI is acquired by sending pilot signal in the uplink transmission.

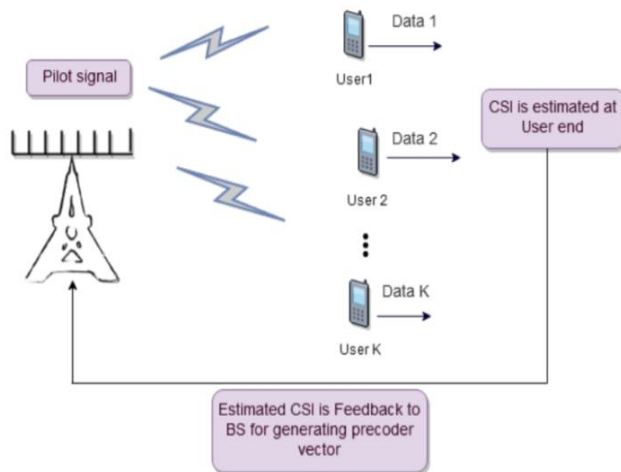

Figure 5: Downlink transmission in an FDD Massive MIMO system

IV. PROPOSED METHODOLOGY

The MIMO-OFDM device modified into applied with the useful resource of MATLAB/SIMULINK. The execution device is binary facts this is modulated the use of QAM and mapped into the constellation elements.

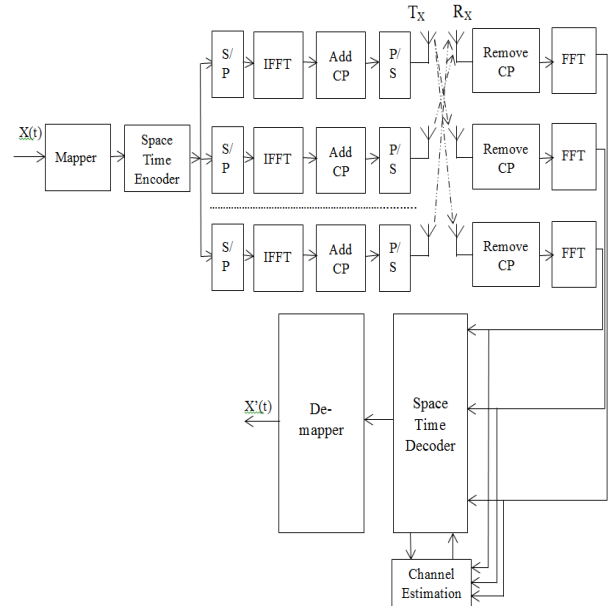

Figure 6: Massive MIMO System Models with Channel Estimation Technique

The virtual modulation scheme will transmit the records in parallel by means of manner of assigning symbols to every sub channel and the modulation scheme will determine the phase mapping of sub-channels thru a complex I-Q mapping vector show in figure 5. The complicated parallel facts stream must be converted into an analogue signal this is suitable to the transmission channel.

The complicated parallel facts stream has to be transformed into an analogue sign that is suitable to the transmission channel. It is performed to the cyclic prefix add to the baseband modulation signal because the baseband signal is not overlap. After than the signal is splitter the two or more part according to the requirement.

V. CONCLUSION

This paper has dealt with channel estimation for single cell Massive MIMO system with no interference from other cells. However, it is necessary to estimate the channel of a single cell, when the signal from other cells interferes with the signal of the desired cell. Consider the case, where BS estimates not only the channel parameters of desired links in a given cell but also, those of the interference links from adjacent cells. In multi-cell case, it is necessary to study the interference links, in order to have interference coordination.

In such scenarios, BS has to collect information regarding CSI of both the desired links within the cell and interference links from its neighboring cells. Under undesirable finite scattering scenario, the combined channel matrix can be modeled as low-rank matrix. Therefore, the analysis presented in this work can be extended to a multi-cell scenario.

REFERENCE

- [1] H. Q. Ngo A. Ashikhmin H. Yang E. G. Larsson T. L. Marzetta "Cell-free massive MIMO versus small cells" *IEEE Trans. Wireless Commun.* vol. 16 no. 3 pp. 1834-1850 Mar. 2017.
- [2] Huang A. Burr "Compute-and-forward in cell-free massive MIMO: Great performance with low backhaul load" *Proc. IEEE Int. Conf. Commun. (ICC)* pp. 601-606 May 2017.
- [3] Q. Huang A. Burr "Compute-and-forward in cell-free massive MIMO: Great performance with low backhaul load" *Proc. IEEE Int. Conf. Commun. (ICC)* pp. 601-606 May 2017.
- [4] H. Q. Ngo A. Ashikhmin H. Yang E. G. Larsson T. L. Marzetta "Cell-free massive MIMO: Uniformly great service for everyone" *Proc. IEEE Int. Workshop Signal Process. Adv. Wireless Commun. (SPAWC)* pp. 201-205 Jun. 2015
- [5] E. Nayebi A. Ashikhmin T. L. Marzetta H. Yang "Cell-free massive MIMO systems" *Proc. 49th Asilomar Conf. Signals Syst. Comput.* pp. 695-699 Nov. 2015.
- [6] F. Rusek, D. Persson, B. K. Lau, E. G. Larsson, T. L. Marzetta, O. Edfors, and F. Tufvesson, "Scaling up mimo: Opportunities and challenges with very large arrays," *IEEE Signal Process. Mag.*, vol. 30, no. 1, pp. 40–60, Jan 2013.
- [7] L. Lu, G. Y. Li, A. L. Swindlehurst, A. Ashikhmin, and R. Zhang, "An overview of massive MIMO: Benefits and challenges," *IEEE J. Sel. Topics Signal Process.*, vol. 8, no. 5, pp. 742–758, Oct 2014.
- [8] S. Payami and F. Tufvesson, "Channel measurements and analysis for very large array systems at 2.6 ghz," *Proc. 6th Eur. Conf. on Antennas and Propag. (EUCAP)*, pp. 433–437, March 2012.
- [9] A. F. Molisch, V. V. Ratnam, S. Han, Z. Li, S. L. H. Nguyen, L. Li, and K. Haneda, "Hybrid beamforming for massive MIMO: A survey," *IEEE Comm. Mag.*, vol. 55, no. 9, pp. 134–141, 2017.
- [10] F. Sohrabi and W. Yu, "Hybrid digital and analog beamforming design for large-scale antenna arrays," *IEEE Journal of Selected Topics in Signal Processing*, vol. 10, no. 3, pp. 501–513, April 2016.
- [11] O. E. Ayach, S. Rajagopal, S. Abu-Surra, Z. Pi, and R. W. Heath, "Spatially sparse precoding in millimeter wave MIMO systems," *IEEE Transactions on Wireless Communications*, vol. 13, no. 3, pp. 1499–1513, March 2014.
- [12] I. Ahmed, H. Khammari, A. Shahid, A. Musa, K. S. Kim, E. D. Poorter, and I. Moerman, "A survey on hybrid beamforming techniques in 5G: Architecture and system model perspectives," *IEEE Communications Surveys and Tutorials*, vol. 20, no. 4, pp. 3060–3097, Fourthquarter 2018.
- [13] S. Payami, N. Mysore Balasubramanya, C. Masouros, and M. Sellathurai, "Phase shifters versus switches: An energy efficiency perspective on hybrid beamforming," *IEEE Wireless Communications Letters*, vol. 8, no. 1, pp. 13–16, Feb
- [14] Akhilesh Venkatasubramanian, Krithika.V and Partibane. B, "Channel Estimation For A Multi-User MIMO-OFDM- IDMA System", *International Conference on Communication and Signal Processing*, April 6-8, 2017, India.