

Thrash Deplorer System Using IoT Through Web Application

K. Lalith Kishore^{1*}, P. Jaswanth², S.B.T. Abhyuday³, Y. Jayasairam⁴

^{1,2,3,4}Dept. Of Electronics and Communication Engineering, JNTUA College of Engineering, Pulivendula, Andhra Pradesh, India

Available online at: www.ijcseonline.org

Accepted: 14/Nov/2018, Published: 30/Nov/2018

Abstract- Today's generation has a great need of cleanliness and health plays an important role in their life so that our surroundings must be clean. This can be achieved through this paper and in this paper it mainly deals about the overfilling of garbage bins in our society. The bin status can be observed by the municipal officer in his office and knowing continuous monitoring of the bin status through the web application using IoT. The filling of the bins can be determined by two methods one is by weight and the other is the level. This can reduce the manual monitoring and continuous keen observation on the bin can be prevented. In this paper mainly deals about the sensors like weight and ultrasonic sensors, a node Microcontroller Unit (MCU) and an IoT platform which acts as an interface with the hardware part and the software part in which the application is present. The hardware part can be connected on the Arduino in which all the sensors can be interfaced along with NodeMicroControllerUnit (MCU).

Keywords- NodeMCU, IoT, Arduino, weight and ultrasonic sensors.

I. INTRODUCTION

India is a developing country and we are taking necessary steps in the state of up gradation, but here the cleanliness also plays an important role in up gradation. Garbage may contain unwanted material left over from different areas and from different sectors. These trash bins are overfull due to waste materials and the junk materials being dripped out from the bins in our society. Due to over flow of trash bins and vast amount of insects and mosquitoes lays on it. This leads to affect the human health resources. Taking a big challenge in our urban cities is solid waste management. Hence, smart trash bin is a system which can destroy this problem or at least reduce it. This project is related to the "Smart City" and based on "Internet of Things" (IoT). So it can use to changing the life style of the people in our civilization .so for that cleanliness and the cleanliness is appears and usage of the trash bins. Internet of the things, it is concept surrounding areas with connected wired and wireless channel without user intervention.

In this paper, the smart trash bins are connecting with internet to get the real time updates of the cans. The arduino is interfaced with the weight sensor and node MCU is connected to the ultrasonic sensor, by Wi-Fi module present in the node MCU updates the sensor data to things speak and this act as interface to send the data to authorized officer at the municipality region office. The message alert can be sent to local municipal drivers and by this they can collect the garbage waste form trash bins.

It is used to communicate and transfer the information through advanced intelligent sever user. In today generation the communication is increased very rapidly by introducing the various kinds of sensors and communication modules and through the communication network channel are Wi-Fi, GSM, LITE and VOTLE considering of these kind of application. The technology is upgraded through IoT is improved a lot and lots of applications is to be done. Owing the IoT services through solid waste management can be taken as challenge by industry and government of the India had taken machine is called swatch hart. In the past days, we are facing lots of problem in solid waste management system if the trash are filled and overflow in some areas. The municipal organizations are detected and find the cans and dropped into the containers of the trucks. In this process having the demerits are waste of time, overfilling of the cans and lots of effort by municipality employers and health hazards can be sourced.

II. LITERATURE SURVEY

One of the major problems considered environment is waste which is potential threat for public health and sanitation still remains limited. Efficient waste collection must be considered not only for health but also plays a major role in the development of smart cities. In regarding to this a smart bin must be there which not only collects but also updates. So in order to achieve these goals we require a particular platform where both the hardware and software plays a

major role in the development of smart cities. This can be achieved through the IoT and can make the work easily [1], [2]. In cities there are so many trash bins present so in order to differentiate one bin from other using RFID tags which is a very costly process. so that as bin location is static taking that as an advantage giving the bin, different numbers and those are stored in the web application in order to differentiate bins and know their statuses [3].The both GPS and GSM modules plays an important role to find out the location and update the status of the bin if it is filled so that message can be sent to municipal department. Here again the static position of the bin can be used for the location updating as it cannot be moved so that location is kept in the software and sending message there is a gateway which sends messages through internet as it doesn't require any module for sending the messages so it reduces the overall modules[4].The Amazon web services is one of the application which gives us a user id and password which is used as web platform for the whole monitoring of the data but an application can be developed without the private platforms and in that using API keys we can get the whole sensor data so further can be processed[5].

III. METHODOLOGY

The whole project contains the following modules collecting data from sensors. Pushing the statistics onto cloud at

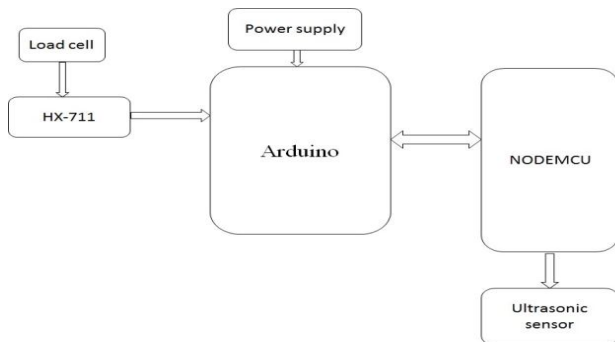

Arduino

Arduino Uno is the development board that we used in this paper as main key component to get either analog or digital information from the sensors, whether it is a digital or analog then it pushes the information into the node MCU.

Node MCU

Node MCU is exposed bases IoT platform in include firmware which runs on the ESP8266 Wi-Fi system and hardware which is based on ESP12 and firmware uses the LUA scripting language its latest version of the boat as following parameters. its 10digital and analogy pins .it use 802.11Wi-Fi standards the operating voltage 3.3 to 6V.AND operating frequency is 2.4 to 2.6GHz and it is interactive programmable and it is the low cost module it has in built Wi-Fi module.

specified intervals. Accessing statistical data using web/mobile application.

Collecting data from sensors:

Ultrasonic and weight Sensors to be placed on garbage bins data is collected from the ultrasonic sensor information and weight sensor information. The ultrasonic sensor sends triggering pulses on the garbage and according to it receives an echo signal to calculate level. The weight sensor converts the load into an electrical signal which is given to A/D converter for the weight information

Pushing the statistics onto cloud at specified intervals:

The whole data is collected and is pushed into the IOT cloud platform and the statistics are observed. This data is given to the cloud database and it is given at specific intervals.

Accessing statistical data using web/mobile application:

Each bin is given a tag id and each id information is in the web application developed. In the web application the area cards are displayed where the status of each bins in that area is determined. From there it can be known the bin levels of different areas and if the bin is filled then an alert can be sent to the municipal driver.

Proposed Methods:

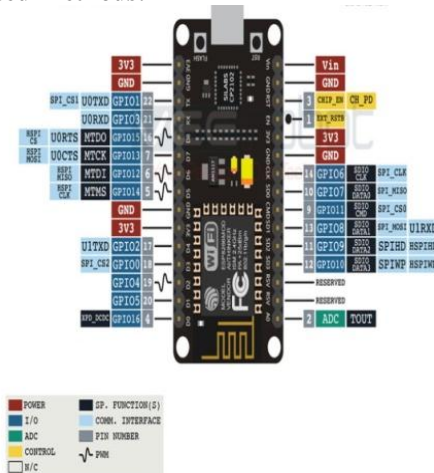

Ultrasonic Sensor:

An ultrasonic sensor that senses the distances range through the waves produced by it and particularly those waves are in the range of ultrasonic range nearly 40 kHz. The main principle involved in the ultrasonic sensor is the sound waves are generated through the trigger pin and these waves are travelled in the bin and if any obstacles gets hitted means then the wave gets reflected back to the sensor and in the sensor through the echo pin the waveform is collected and processed to the arduino by the ultrasonic sensor.



This distance can be measure using the following formula

$$\text{distance} = \frac{\text{speed of sound} \times \text{time taken}}{2}$$

Weight Sensor:

A load cell measures the specific force and other force applied are being ignored load cell operate in order under compression due to sensitivity of the sensors load cell are being designed with a small element like made of metal structure. HX711 IC is 24 bit A/D converter with as functioning characteristic of fast response, high integration design for weigh scale and industrial operation. Where the performance and reliability can be improved.



HX711 IC

Here the electrical signals that are produced by Weight cell are in scarce mill volts, so they necessity to be extra amplified by some amplifier and hence HX711 Balancing Sensor derives keen on scenario. HX711 Weighing Sensor Module has a 24 high precision A-D converter (Analog to digital converter). It has two analog input channels and we can get gain up to 128 bytes programming these channels. To drives the load of the trash bins the information is feed to the arduino and it displays the weight of the trash bin.

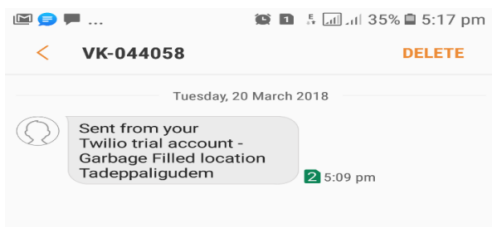
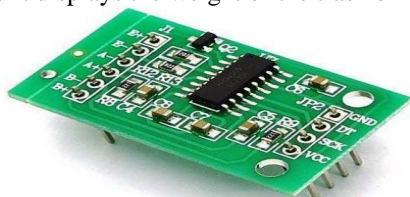

Experimental Results:

It is the stored data in the data base where the data can be retrieved from the database into the web application that we developed through the software c#.net

created_at	entry_id	field1	field2
02-Mar-18 3:44 PM	105	8	2.80
02-Mar-18 3:44 PM	106	8	3.66
02-Mar-18 3:45 PM	107	8	3.96
02-Mar-18 3:45 PM	108	8	3.92
02-Mar-18 3:46 PM	109	8	4.42
02-Mar-18 3:46 PM	110	8	4.39
02-Mar-18 3:46 PM	111	8	4.44
02-Mar-18 3:47 PM	112	8	3.63
02-Mar-18 3:47 PM	113	8	3.31
02-Mar-18 3:48 PM	114	8	4.01
02-Mar-18 3:48 PM	115	8	4.07
03-Mar-18 9:29 AM	116	0	0.37

It is the graphical representation of the level information that lies on y axis and on the x axis the time and the other graph represents the same coordinates but on y axis the weight information is displayed

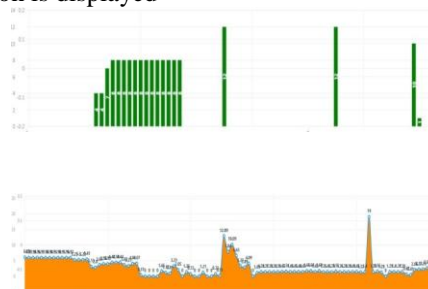

In this paper we not using any GPS module as bin locating is static we are directly updating static locating in the software. If any location changes the we can update it in the software



Without using the GSM module we are using the message gate way for sending message to the respective municipal department to clean up the bin in this message it contains static location of the bin where bin is to be emptied.

IV. CONCLUSION AND FUTURE SCOPE

In this paper, a combinational system of Wi-Fi modem, IoT, GSM, Ultrasonic Sensor and weight sensor is made a path for well-organized and cost-effective trash collection. Here in this system there is cloud catalog which stores the whole information and static locations of the different trash bins in various locations. The cloud platform used here will acts as

an interface for the web application and sensor data collection. So therefore a complete graphical analysis of the whole sensor data can be obtained through the web application and alert is sent to the department. By this technology we can achieve our goals through the clean and green society.

Here the separation of dry and wet waste are not mentioned in this paper but in future by the weight analysis and the humidity present represents whether the waste is dry or wet and moreover the driver can be directly given the bin location through the web application and it also can give the short distance for the driver to reach the bin using algorithms.

REFERENCES

- [1]. Dr. LakhimiGogoi,"Municipal solid waste disposal: a case study in Guwahati city to mitigate the manmade disaster", IOSR Journal of Humanities and Social Science (IOSR-JHSS) Volume 9, Issue 3(Mar. Apr. 2013), PP 55 60 e ISSN:22790837, p-ISSN: 2279-0845.
- [2]. Saha, H. N., Auddy, S., Pal, S., Kumar, S., Pandey, S., Singh, R., Saha, S. (2017). Waste management using Internet of Things (IoT). 2017 8th Annual Industrial Automation and Electromechanical EngineeringConference(IEMECON).doi:10.1109/iemeccon.2017.8079623
- [3]. Kumar, N. S.Vuayalakshmi, B.Prarthana, R. J., & Shankar, A. (2016). "IOT based smart garbage alert system using Arduino UNO". 2016 IEEE Region 10 Conference (TENCON). doi: 10.1109 /tencon. 2016. 7848162 .
- [4]. Sunil Raj Thota, S. Neelima, K. V. N. Lalitha Pruthvi, K. Mounika, M. Pravallika , Mrs. N. Sowmya, Asst. Proof "Smart Trash Can Monitoring System usingIoT-Creating Solutions for Smart Cities "International Research Journal of Engineering and Technology(IRJET)e-ISSN: 2395-0056p-ISSN: 2395-0072Volume: 05 Issue: 03 | Mar-2018
- [5]. Akshatha.Y1,TasbihaAafreen.G,NandiPriyaBai.M.L , Jyothi.M , Anitha.R". IoT Based Garbage and Street Light Monitoring System" International Journal of Engineering Science and Computing, May 2017 Volume 7 Issue No.5