

# A Design and Implementation of Wireless Energy Harvesting (WEHIoT)

Supriya M<sup>1\*</sup>, Chetana Srinivas<sup>2</sup>

<sup>1,2</sup>Department of CSE, East West Institute of Technology, Bangalore, India

DOI: <https://doi.org/10.26438/ijcse/v7si15.192197> | Available online at: [www.ijcseonline.org](http://www.ijcseonline.org)

**Abstract:** Internet of Things (IoT) is an emerging computing concept that describes a structure in which everyday physical objects, each provided with unique identifiers, are connected to the Internet without requiring human interaction. Long-term and self-sustainable operation are key components for realization of such a complex network, and entail energy-aware devices that are potentially capable of harvesting their required energy from ambient sources. Among different energy harvesting methods such as vibration, light and thermal energy extraction, wireless energy harvesting (WEHIoT) has proven to be one of the most promising solutions by virtue of its simplicity, ease of implementation and availability. In this proposed project, we present an overview of enabling technologies for efficient WEHIoT, analyze the life-time of WEH-enabled IoT devices.

**Keywords**—IOT, Node MCU, Relays, GasSensor

## I. INTRODUCTION

Internet of Things (IoT) is an intelligent infrastructure of uniquely identifiable devices capable of wirelessly communicating with each other, services and people on a large scale, through the Internet.

An IoT system consists of sensors/devices which “talk” to the cloud through some kind of connectivity. Once the data gets to the cloud, software processes it and then might decide to perform an action, such as sending an alert or automatically adjusting the sensors/devices without the need for the user as shown in fig 1. But if user input is needed or if the user simply wants to check in on the system, a user interface allows them to do so. Any adjustments or actions that the user makes are then sent in the opposite direction through the system: from the user interface, to the cloud, and back to the sensors/ devices to make some kind of change.

That’s how an IoT system works at a high level. Now we’ll take a deeper dive into each of these components to explain what they are, how they work, and important considerations for your organization as you consider building and/or implementing IoT solutions. IoT aims at making the Internet ubiquitous and pervasive and has the potential to affect the quality of life for the users in many aspects. The networked heterogeneous devices connected in an IoT structure are typically equipped with sensors, controlling processors, wireless transceivers, and an energy source (e.g., a battery) to monitor their environment and send/receive data.

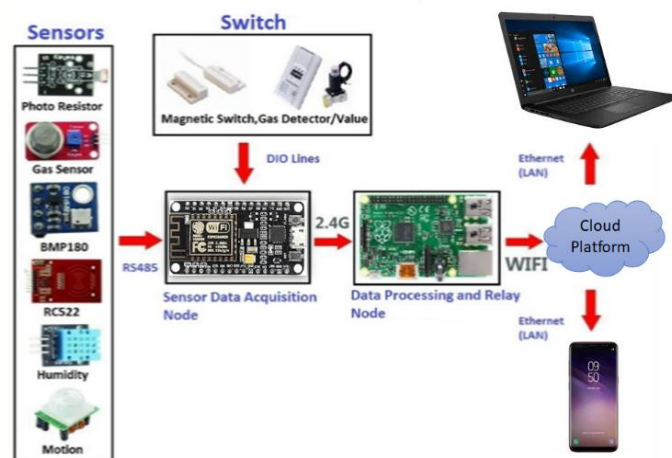

Figure 1 .IoT System using Node MCU

Applications envisioned for IoT span a wide range of fields like home automation, healthcare, surveillance, transportation, smart environments and many more. One of the dominant barriers in implementing such a grandiose scheme is supplying adequate energy to operate the network in a self-sufficient manner without compromising quality of service. Therefore, it is imperative to improve the energy efficiency and longevity of devices in IoT. Although there are numerous methods to achieve energy efficiency, such as using lightweight communication protocols or adopting low-power radio transceivers, the recent technology trend in energy harvesting provides a fundamental method to prolong battery longevity. Thus, energy harvesting is a promising approach for the emerging IoT. Practically, energy can be harvested from environmental sources, namely, thermal, solar, vibration, and wireless radio-frequency (RF) energy sources.

While harvesting from the aforementioned environmental sources is dependent on the presence of the corresponding

energy source, RF energy harvesting provides key benefits in terms of being wireless, readily available in the form of transmitted energy (TV/radio broadcasters, mobile base stations and hand-held radios), low cost, and small form factor implementation. This article presents an overview of wireless energy harvesting units in the context of wireless energy harvesting-Internet of Things (WEH-IoT) systems. In this scenario, multiple sensor nodes typically transmit data to a common sink node. The sink node, also known as gateway, is connected to the network and is accessible to the outside world over the Internet.

## II. RELATED WORK

A state-space model of wireless power transfer (WPT) systems [1] to be used for the purpose of state estimation and controller design considering the internet of things (IoT) communication networks. After expressing the WPT systems into a state-space linear equation, the elements of IoT such as sensors are deployed to obtain the state information

Among different energy harvesting methods such as vibration, light and thermal energy extraction,[2] wireless energy harvesting (WEH) has proven to be one of the most promising solutions by virtue of its simplicity, ease of implementation and availability. In this article, we present an overview of enabling technologies for efficient WEH, analyse the life-time of WEH-enabled IoT devices, and briefly study the future trends in the design of efficient WEH systems and research challenges that lie ahead.

Since each power beacon has a separate local oscillator and controller,[3] it is very challenging to achieve frequency and phase synchronization among power beacons, which is the prerequisite for optimal distributed beamforming. In this paper, we study the performance of the distributed wireless power transfer system with or without the frequency and phase synchronization. Based on the experiment and simulation results, we show that the distributed wireless charging is advantageous in terms of the coverage probability as long as the optimal distributed beamforming is available in the distributed wireless power transfer system.

The deployment [4] of networks composed of several radio frequency (RF) based wireless power transfer nodes will be an indispensable component of future Internet of Things (IoTs). The natural objective of such networks, so called the wireless power transfer networks (WPTNs), is to charge the energy receiver devices wirelessly as quickly as possible; i.e. maximizing the transmitted power. However, a safe-charging WPTN must also comply with the RF exposure regulations and keep electromagnetic radiation (EMR) under a predefined threshold. In this paper we consider the problem of maximizing the transmitted wireless power to the energy receivers with subject to the safety constraints.

We introduce two fully-distributed charging algorithms where the energy transmitters communicate only with the sensors in their communication range to obtain their measurements, perform simple computation steps to adjust their power levels and in turn satisfy safety constraints without any global information. To support the demand for energy autonomy, many of the future IoT edge devices will be powered from non-conventional, energy [6] harvesting and wireless power sources. While convenient, sustainable, and robust, wireless power transfer (WPT) exhibits limited efficiency compared with the traditional wired power approaches, presenting a primary design challenge for practical IoT systems. Non-radiative mid-range WPT from a single power source to several power loads and from several power sources to a single power load has recently been experimentally demonstrated. Alternatively, WPT among multiple, simultaneously transmitting and receiving devices is a primary concern in future IoT systems with numerous interconnected heterogeneous objects.

Furthermore, the dynamic nature of certain distributed IoT systems has a significant effect on WPT interactions among the numerous, mobile in space power devices. WPT that exploits the lossless characteristics of strong-coupled resonant regime is explored in this work as a method for efficiently transferring power among multiple, dynamically connected and disconnected IoT end devices. The efficiency of the power transfer is investigated in dense and sparse IoT systems in terms of the number of IoT devices located within limited space. Based on the results of this work, interactions among wirelessly powered devices have significant effect on the power transfer. Efficiency of power transfer increases with increasing transmitter-receiver coupling.

Alternatively, densely clustered power transmitters or receivers may degrade the system-wide power transfer and efficiency. Intuition behind systematically optimized utilization of the WPT-based energy budget in future IoT systems is also provided. As portable mobile devices become pervasive, charging their [5] batteries has become a critical problem. The wireless power transfer (WPT) is emerging as a promising technology for wirelessly charging electronic devices. WPT has been an exciting emerging technology in consumer electronics, replacing wired chargers and eliminating the need of power cords and chargers. WPT is capable of completely disrupting the way that mobile devices, cars, and aerial vehicles, operate and obtain energy. This paper provides a brief introduction to WPT.

## III. METHODOLOGY

### PROPOSED BLOCK DIAGRAM

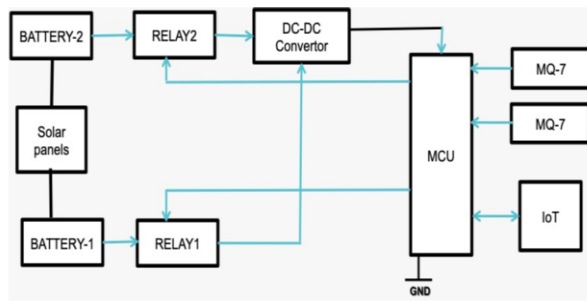

Figure 2:Proposed System block diagram

As shown in fig2, MQ7 Sensors are connected to nodemcu that is ESP32S.ESP32 is a single 2.4 GHz Wi-Fi-and-Bluetooth combo chip designed with the TSMC ultra-low-power 40 nm technology. These sensor data is periodically updated in Blynk app present in smart phone. If any IOT device encounters power low, load is switched from one to another relay. These relays will be powered by batteries which are charged regularly with solar panels. once the load is switched an notification will be sent to Blynk app requesting for on and off mode.

The following components are used to realize WEHIoT.

- A. Node MCU (ESP32S)
- B. GasSensor(MQ-7)
- C. MT3608
- D. Relays
- E. Blynk Application in mobile phone
- F. Solar Panels

NODE MCU (ESP32S)

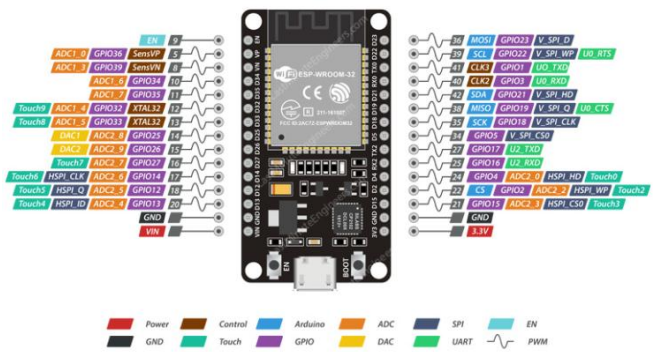

Figure 3 NodeMCU 32S

Node MCU is an open IoT platform.Pin details are as shown in fig3.ESP32 is a single 2.4 GHz Wi-Fi-and-Bluetooth combo chip designed with the TSMC ultra-low-power 40 nm

technology. It is designed to achieve the best power and RF performance, showing robustness, versatility and reliability in a wide variety of applications and power scenarios. The ESP32 series of chips includes ESP32-D0WDQ6, ESP32-D0WD, ESP32-D2WD, and ESP32-S0WD. ESP32 based nodeMCU has 8 ADC channels, on pins 32 through 39, but only 6 are actually usable since pins 37 and 38 are not exposed from the chip to a header pin. By default the ESP32 has a 12 bit resolution meaning the analogRead () function will return a value from 0-4096. If we divide 3.3 by 4096 you can see that we can decipher between voltages of about .8 millivolts using this ADC. The ESP32 is clearly superior when it comes to analog output. Not only does it handle its pwm generation independent from the main processor, but it also has a true DAC, which means it doesn't just simulate different voltages by outputting a PWM signal, it can actually output voltages between 0 and 3.2 volts.

Gas Sensor (MQ7)



Figure 4 MQ7 Gas Sensor

CO is toxic to humans when the concentration is above 35 ppmis as shown in fig 4. The source of CO is produced from the partial oxidation of carbon containing compounds. For example, the gas does not burn fully. Particulate matter (PM) is a mixture of small particles found in the air . Small particles with a diameter of 10 μA(Micro ampere) or less can be inhaled that causing serious health issues to lungs. Particles with a diameter less than 2.5 μm(micro mole) (PM2.5) can go deeper into our lungs and they can be more dangerous than Bigger particles ranged between 2.5 and 10 μm (PM10).

The MQ-7 is a Carbon Monoxide (CO) sensor suitable for sensing CO concentrations in the air. It can detect CO-gas concentrations anywhere from 20 to 2000 ppm.It make detection by method of cycle high and low temperature, and detect CO at low temperature. It is widely used in domestic CO gas leakage alarm, industrial CO gas alarm and portable CO gas detector

MT3608



Figure 5 MT3608

The MT3608 is a constant frequency, 6-pin SOT23 current mode step-up converter intended for small, low power applications as shown in fig 5. The MT3608 switches at 1.2MHz and allows the use of tiny, low cost capacitors and inductors 2mm or less in height. Internal soft-start results in small inrush current and extends battery life. The MT3608 features automatic shifting to pulse frequency modulation mode at light loads. The MT3608 includes under-voltage lockout, current limiting, and thermal overload protection to prevent damage in the event of an output overload. The MT3608 is available in a small 6-pin SOT-23 package.

#### RELAYS:



Figure 6 Relays

A relay is an electromagnetic switching device consisting of an armature which is moved by an electromagnet to operate one or more switch contacts. It is as shown in fig 6. Some advantages of relays are that they provide amplification and isolation and are straightforward. Here we are using a 5V 4-channel relay interface board, and each channel needs a 15-20mA driver current. It can be used to control various appliances and equipment with large current

relays that work under AC250V 10A or DC30V 10A. It has a standard interface that can be controlled directly by a microcontroller.

#### SOLAR PANELS:



Figure 7 Solar Panels

Solar cells are merged into larger units – the panels – in panel production. They are framed and weather-proofed. The solar energy panels are final products, ready to generate power. Sunlight is converted into electrical energy in the panels as shown in fig 7. The direct current produced this way is converted to alternating current by a device called an inverter so that it can be fed into the utility grid or, if applicable, straight into the house.

#### BLYNK APPLICATION ON SMARTPHONES

Blynk is a third-party app which has interfaces in both iOS and Android phones, mainly used to control a Node MCU. The graphic interface can be built in the digital dashboard by simply dragging and dropping widgets. It is provided as a tool for users to make IoT design automation.

The proposed system is implemented using a Node MCU due to its cost effectiveness and ease of development. In this method, all the sensors are connected to the Node MCU board and the results can be seen in a smart phone via a Blynk app.

#### IV. Flow chart:

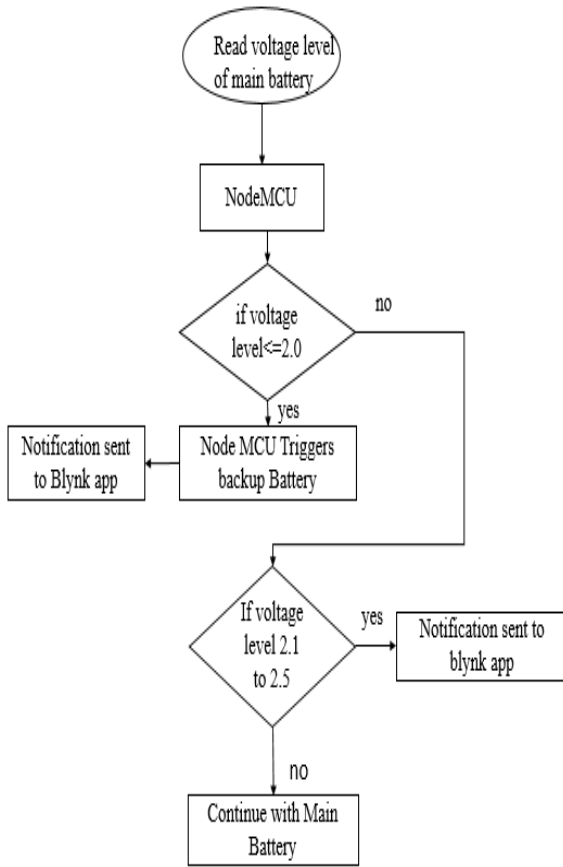

**V. RESULTS AND DISCUSSION**

The result that have been obtained from above setup can be seen in Blynk app as captured below.

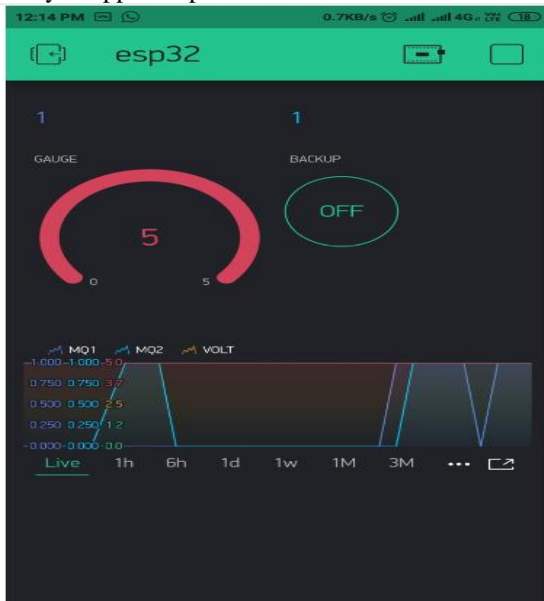

Figure 8 When voltage is above threshold

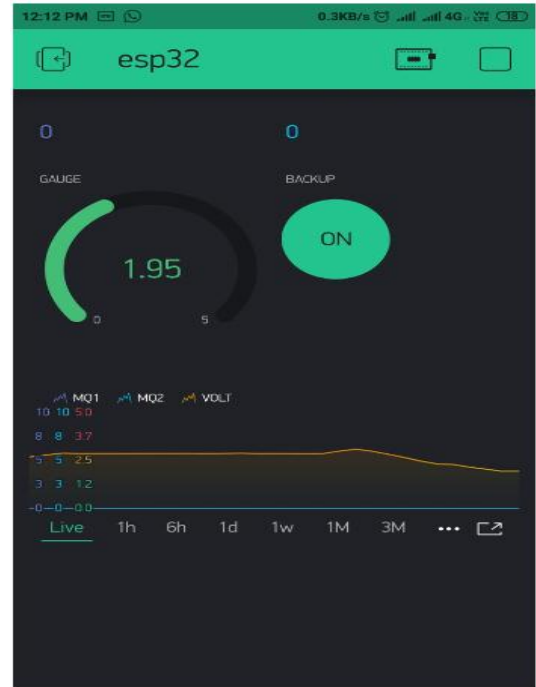

Figure 9 When threshold voltage drops

**VI. CONCLUSION AND FUTURE SCOPE**

The energy harvesting techniques for Internet of Things (IoT) services and applications. Over 50 billion multi-role devices, capable of sensing and actuating, will be installed by 2025, which shows a tremendous growth in the number of devices and creates new challenges and opportunities. A major burden is powering these devices, as using the main power and batteries is mostly restricted due to the small sizes of many devices and the fact that these devices are installed in hard-to-reach areas, where regular battery maintenance is impractical and very expensive. A viable solution is to use energy harvesting techniques to harvest energy from environment and provide enough energy to the devices to perform their operations. This will significantly increase the device life time and eliminate the need for the battery as an energy source

**REFERENCES**

- [1] Intel. (2017) The internet of things starts with intel inside. [Online]. Available: <https://www.intel.com/content/www/us/en/internet-of-things/overview.html?cv=1&session-id=a72c71a6dead059d17510ab183b548c4>
- [2] Intel. Guide to iot, year = 2017, url = <http://www.intel.com/content/www/us/en/internet-of-things/infographics/guide-to-iot.html>, urldate = 2017-11-14.
- [3] K. Wang, Y. Wang, Y. Sun, S. Guo, and J. Wu, "Green industrial internet of things architecture: An energy-efficient perspective," IEEE Communications Magazine, vol. 54, no. 12, pp. 48–54, Dec. 2016.

- [4] H. Jayakumar, K. Lee, W. S. Lee, A. Raha, Y. Kim, and V. Raghunathan, "Powering the internet of things," in Proceedings of the 2014 international symposium on Low power electronics and design. ACM, 2014, pp. 375–380. <http://www.beechamresearch.com/article.aspx?id=4>
- [6] F. Akhtar and M. H. Rehmani, "Energy replenishment using renewable and traditional energy resources for sustainable wireless sensor networks: A review," *Renewable and Sustainable Energy Reviews*, vol. 45, pp. 769 – 784, 2015. [Online]. Available: <http://www.sciencedirect.com/science/article/pii/S1364032115001094>
- [7] "Energy harvesting for self-sustainable wireless body area networks," *IT Professional*, vol. 19, no. 2, pp. 32–40, March 2017.
- [8] S. Chalasani and J. M. Conrad, "A survey of energy harvesting sources for embedded systems," in *IEEE SoutheastCon 2008*. IEEE, 2008, pp. 442–447.
- [9] F. Yildiz, "Potential ambient energy-harvesting sources and techniques," 2009.
- [10] V. Raghunathan and P. H. Chou, "Design and power management of energy harvesting embedded systems," in Proceedings of the 2006 international symposium on Low power electronics and design. ACM, 2006, pp. 369–374.
- [11] D. Pimentel and P. Musílek, "Power management with energy harvesting devices," in *Electrical and Computer Engineering (CCECE), 2010 23rd Canadian Conference on*. IEEE, 2010, pp. 1–4.
- [12] W. K. Seah, Z. A. Eu, and H.-P. Tan, "Wireless sensor networks powered by ambient energy harvesting (wsn-heap)-survey and challenges," in *Wireless Communication, Vehicular Technology, Information Theory and Aerospace & Electronic Systems Technology, 2009. Wireless VITAE 2009. 1st International Conference on*. Ieee, 2009, pp. 1–5.
- [14] S. Sudevalayam and P. Kulkarni, "Energy harvesting sensor nodes: Survey and implications," *IEEE Communications Surveys & Tutorials*, vol. 13, no. 3, pp. 443–461, 2011.
- [15] M. Shirvanimoghaddam, M. Dohler, and S. J. Johnson, "Massive nonorthogonal multiple access for cellular iot: Potentials and limitations," *IEEE Communications Magazine*, vol. 55, no. 9, pp. 55–61, 2017.
- [16] E. Le Sueur and G. Heiser, "Dynamic voltage and frequency scaling: The laws of diminishing returns," 2010.
- [17] M. D. Yin, J. Cho, and D. Park, "Pulse-based fast battery iot charger using dynamic frequency and duty control techniques based on multisensing of polarization curve," *Energies*, vol. 9, no. 3, p. 209, 2016.
- [18] S. F. Abedin, M. G. R. Alam, R. Haw, and C. S. Hong, "A system model for energy efficient green-iot network," in *International Conference on Information Networking (ICOIN)*. IEEE, 2015, pp. 177–182.
- [19] Y. Zeng, B. Clerckx, and R. Zhang, "Communications and signals design for wireless power transmission," *IEEE Trans. Commun.*, vol. 65, no. 5, pp. 2264–2290, May 2017.
- [20] I. Krikidis, S. Timotheou, S. Nikolaou, G. Zheng, D. W. K. Ng, and R. Schober, "Simultaneous wireless information and power transfer in modern communication systems," *IEEE Commun. Mag.*, vol. 52, no. 11, pp. 104–110, Nov. 2014.
- [21] K. Huang, C. Zhong, and G. Zhu, "Some new research trends in wirelessly powered communications," *IEEE Wireless Commun.*, vol. 23, no. 2, pp. 19–27, Apr. 2016.
- [22] F. Yuan, S. Jin, K.-K. Wong, J. Zhao, and H. Zhu, "Wireless information and power transfer design for energy cooperation distributed antenna systems," *IEEE Access*, vol. 5, pp. 8094–8105, 2017.
- [23] D. W. K. Ng and R. Schober, "Secure and green SWIPT in distributed antenna networks with limited backhaul capacity," *IEEE Trans. Wireless Commun.*, vol. 14, no. 9, pp. 5082–5097, Sep. 2015.
- [24] S. Lee, L. Liu, and R. Zhang, "Collaborative wireless energy and information transfer in interference channel," *IEEE Trans. Wireless Commun.*, vol. 14, no. 1, pp. 545–557, Jan. 2015.
- [25] F. Yuan, S. Jin, Y. Huang, K. Wong, Q. T. Zhang, and H. Zhu, "Joint wireless information and energy transfer in massive distributed antenna systems," *IEEE Commun. Mag.*, vol. 53, no. 6, pp. 109–116, Jun. 2015.

### Authors Profile

*Professor Chetana Srinivas* is working as a professor in Department of computer science Engg., East West Institute of Technology. she has published more than 20 research papers in national and international conferences and journals. Her research areas are image processing, cloud and Bigdata.

*Ms Supriya.M* pursued Bachelor of Engg. from VTU University in year 2011. and currently pursuing M.Tech in Department of Computer Network Engineering, VTU since 2017.